

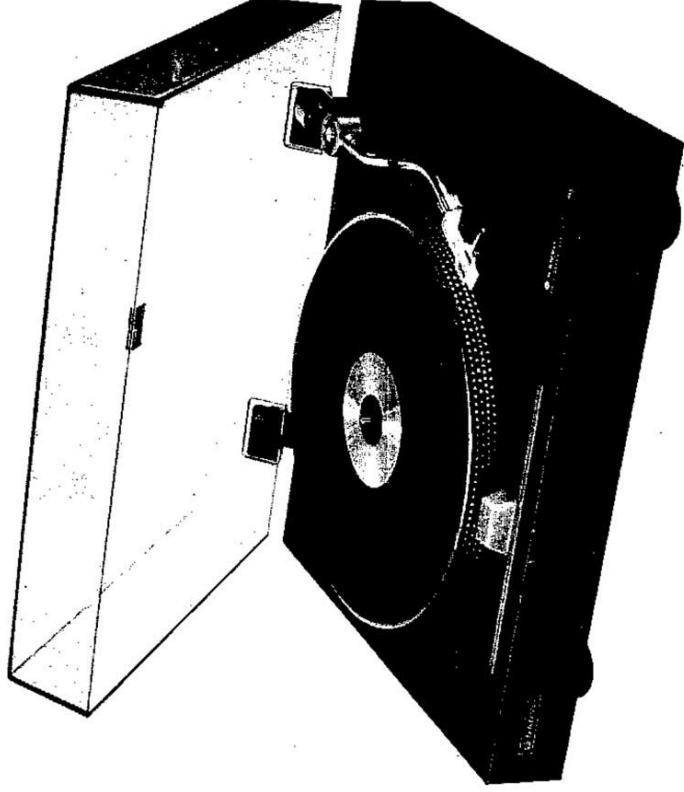

TP 727



# SANYO AUTOMATIC STEREO TURNTABLE OWNER'S MANUAL

## INDEX

	Page	Page	
Introduction .....	1	Cleaning and general remarks .....	4
Place of installation .....	1	Cartridge replacement and adjustment .....	4~5
Preparations for operation .....	1~3	About SANYO .....	5
Identification of parts and instructions for operation .....	3~4	Trouble-shooting guide .....	6
		Specifications .....	6

The SANYO Model TP 727 automatic turntable is designed for use with your audio system. Take the time to read the instructions in this Owner's Manual before setting up your unit, so you can avoid damage due to faulty installation or operating errors. Keep the Manual for future reference.

### PLACE OF INSTALLATION

For safe and satisfactory operation, avoid the following places when installing your unit.

- A place which is directly exposed to sunlight or is near a source of intense heat such as a stove.
- A humid or dusty place.
- A place where there is not sufficient ventilation for heat dissipation.
- A shaky or unstable foundation.

#### NOTE:

- (1) Noise interference may occur if your system is operated near a TV receiver during the reception of television programs.
- (2) Be sure to take power from an AC outlet.

### PREPARATIONS FOR OPERATION

#### 1. UNPACKING AND ATTACHMENT OF DISASSEMBLED PARTS.

Remove all the protective materials and fastening screws used for packing the unit for shipment. Store them for use if the unit is to be transported again. (Fig. 1)

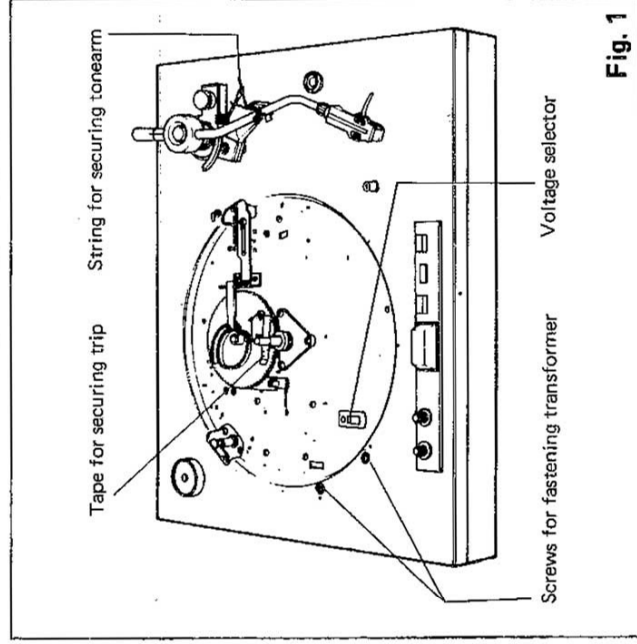

Fig. 1

#### • PROCEDURAL INSTRUCTIONS

- (1) Remove the two screws fastening the power transformer.
- (2) Screw the counterweight onto the rear end of the tonearm as in Fig. 2.
- (3) (The tonearm counterweight is shipped in a plastic bag.) Peel off the tape securing the trip. Make the cutout section of the drive gear meet the turntable shaft. Then, push the trip in the arrow-marked direction. (Fig. 3)
- (4) Be sure that a belt is attached to the turntable. Then, put the turntable onto the turntable shaft.
- (5) The drive belt can be reached through the opening in the turntable. Put it onto the pulley, taking care not to twist it. (Fig. 4)
- (6) Place the rubber mat on the turntable.
- (7) Untie and remove the string holding the tonearm.

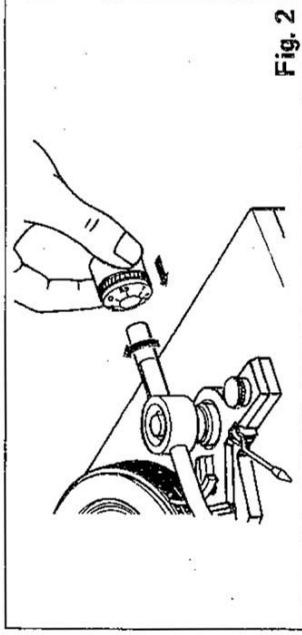

Fig. 2

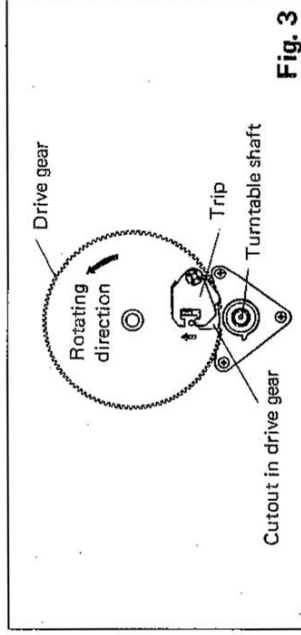

Fig. 3

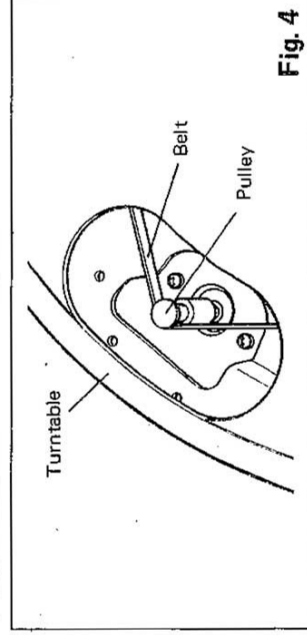
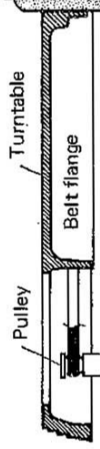

Fig. 4

#### • IMPORTANT

When belting the pulley, the portion of the drive belt running around the belt flange of the turntable should be placed uniformly in the middle of the flange. Unless the belt is kept level, it may run off the flange.



#### 2. ADJUSTMENT OF TONEARM

For the best sound reproduction, the stylus must have an optimum contact pressure. The stylus force should not be too small nor too large. Make necessary adjustment according to the following instructions for maximum enjoyment of music.

#### • BALANCING TONEARM

Prior to making this adjustment, lower the protective cover so that the stylus will not be damaged by accidentally hitting the turntable or the turntable board.

Lift the tonearm off its rest. Turn the counterweight, thus moving it in one direction or the other, until a perfect balance is achieved or and the tonearm stays level. (Fig. 5)

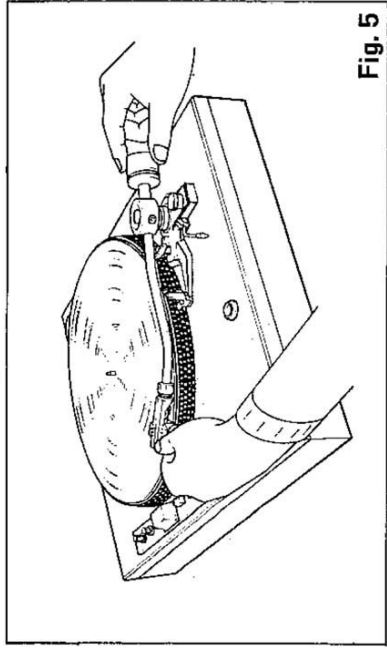

Fig. 5

• **ADJUSTMENT OF STYLUS PRESSURE**

- 1) When the tonearm is balanced, the stylus pressure is zero. Accordingly, turn the dial on the counterweight until the zero mark comes to the line on the tonearm. Be careful not to touch the counterweight while turning the dial. (Fig. 6)
- 2) Turn the counterweight clockwise as seen from the rear (in the arrow-marked direction) until the "2" score on the dial meets the reference line on the tonearm. (Fig. 7) When setting the stylus pressure, squeeze the counterweight with thumb and forefinger, as in Fig. 7, and turn it. Do not touch the dial, which rotates with the counterweight.

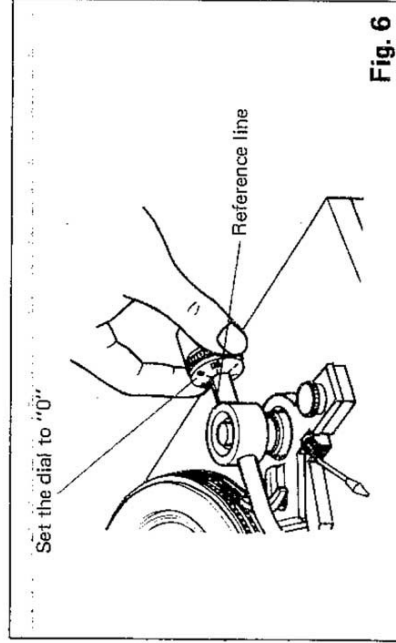

Fig. 6

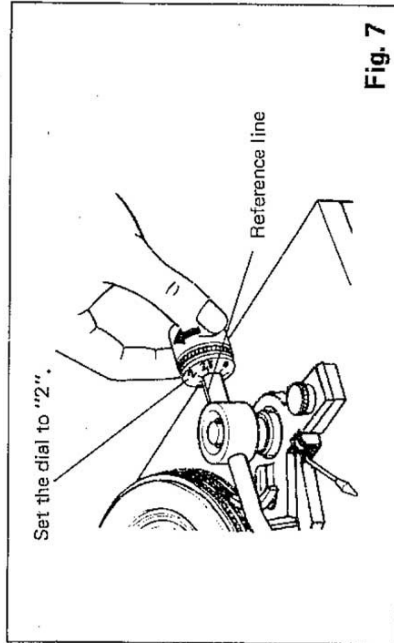

Fig. 7

• **ADJUSTMENT OF ANTI-SKATING FORCE**

To compensate for a skating force which constantly pulls the tonearm toward the center of the record, an offsetting force must be applied. This is the anti-skating force, which must be identical in magnitude to and working in an exactly opposite direction for the skating force. The anti-skating force must be adjusted according to the stylus pressure. If the stylus pressure is set to "2" (grams) as in the previous section, set the anti-skating force adjusting knob to "2" as in Fig. 8.

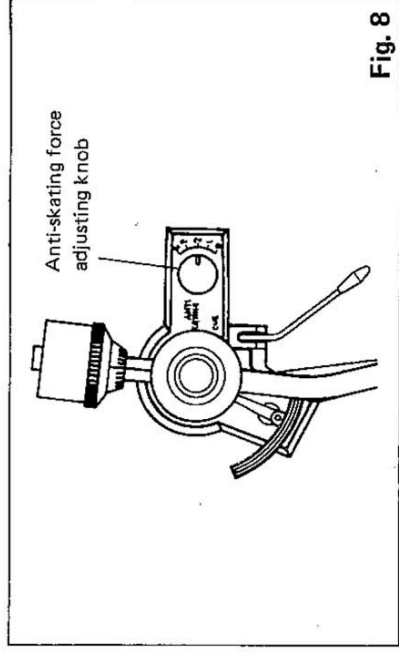

Fig. 8

3. **ATTACHMENT OF DUST COVER (Fig. 9)**

The dust cover of this automatic turntable is detached and packaged separately for shipment. Attach it to the turntable unit before use, following the instructions given below.

- Fit the hinge sections on the cover onto their counterparts on the turntable unit. Slide the cover forward until the hinges become engaged. Hold the cover near the hinges when attaching it.

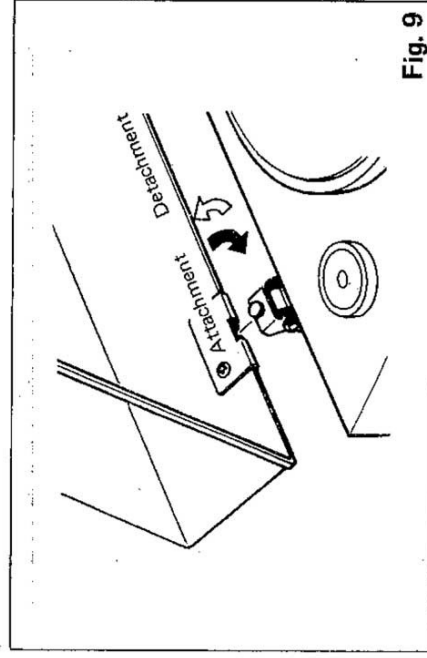

Fig. 9

4. **CORD AND GROUND WIRE CONNECTIONS (Fig. 10)**

• **OUTPUT CORD CONNECTION**

Plug the output cords from the rear of the turntable unit into the PHONO input terminals of the amplifier or the stereo receiver to be used as system components. The red plug is for the R (right) channel and the white plug for the L (left) channel.

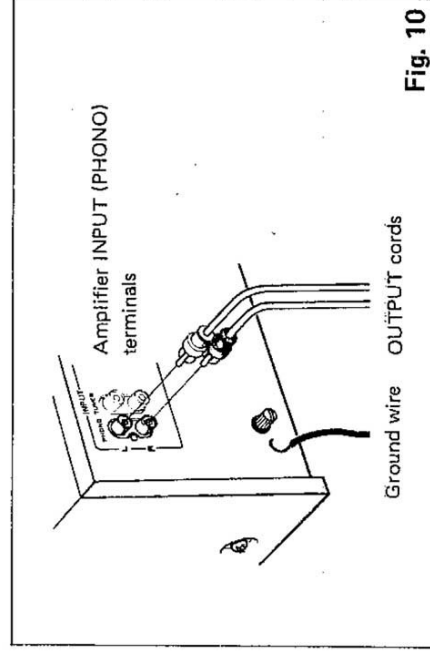

Fig. 10

#### ● GROUND WIRE CONNECTION

Connect a ground wire to the ground (GND) terminal of the amplifier or the stereo receiver in order to eliminate noise and provide protection for your system.

#### NOTE:

With certain types of cartridges or amplifiers, a ground wire may increase noise interference. Should this be the case, avoid using the ground wire.

#### ● POWER CORD CONNECTION

Connect the power cord to a household AC outlet or plug it into the auxiliary power outlet of your amplifier.

#### 5. ADJUSTMENT OF TURNTABLE SPEEDS (Fig. 11)

- (1) Lift the tonearm off its rest and move it toward the center of the turntable, which will then start running.
- (2) Watch the line of dots which appear on the side-wall of the turntable as they are synchronized with the strobescope. When perfect synchronization is achieved, the dots will appear to be stationary at the selected frequency rating and speed.  
There are four lines of dots for speed adjustment: they are, from top to bottom, for 33-1/3 and 45 rpm at the 50 Hz rating, and 33-1/3 and 45 rpm at the 60 Hz rating.
- (3) Make necessary adjustments by means of the fine speed adjusting knob when the dots appear to be moving in either direction.  
Turn the knob toward:  
(+) mark . . . . . The speed will increase.  
(-) mark . . . . . The speed will decrease.

The turntable is running at an optimum speed when the dots seem to stand still.

- The turntable speed should be checked regularly.

(e. g.)

When the selected turntable speed is 45 rpm at the 60 Hz rating, watch the fourth line of dots from the top. Make fine adjustment in case they appear to be moving to the right or to the left.

#### NOTE:

Frequency fluctuations of source power may cause the dots to make wavering movements. The actual turntable speed is not affected by small fluctuations in frequency as this automatic turntable unit is powered by a DC servo motor.

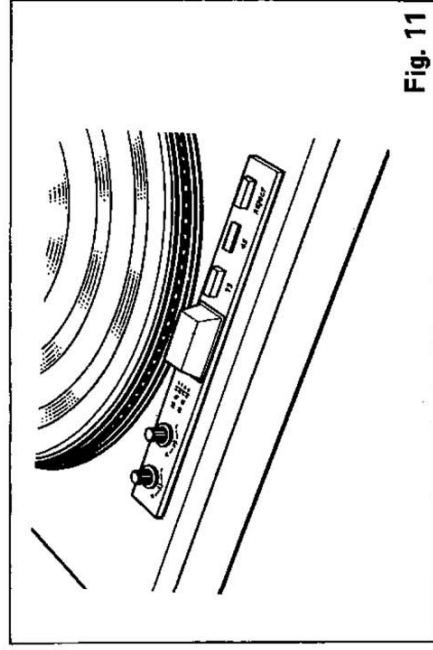

Fig. 11

#### IDENTIFICATION OF PARTS AND INSTRUCTIONS FOR OPERATION (Fig. 12)

#### ● IDENTIFICATION OF PARTS AND THEIR FUNCTIONS

1. 45 rpm record adaptor  
Mount this adaptor onto the turntable spindle when playing a (45 rpm) disc.
2. Turntable and turntable mat
3. Anti-skating force adjuster

This knob is used for adjusting the force which prevents the tonearm from skating toward the center of the record.

4. Cueing lever (tonearm lifter)  
Raise this lever, and the tonearm will be lifted. Push the lever down, and the tonearm will be lowered onto a record more gently than possible by hand. This control can be used when commencing or interrupting performance.

5. Tonearm
6. Lock lever
7. Turntable spindle
8. Tonearm rest
9. Head shell stand
10. Head shell
11. Cartridge
12. Overhang point  
This marks the point for positioning the stylus.

#### 13. Stroboscope

Use these knobs for fine adjustment of turntable speeds the fine adjustment of turntable speeds.

15. Speed selector buttons  
33 (LP) . . . . . Push this button when playing an LP record (33-1/3 rpm).  
45 (EP) . . . . . Push this button when playing a (45 EP) record.

#### 16. REJECT button

Push this button to interrupt record performance, and the tonearm will rise and return automatically to the tonearm rest.

#### 17. Counterweight

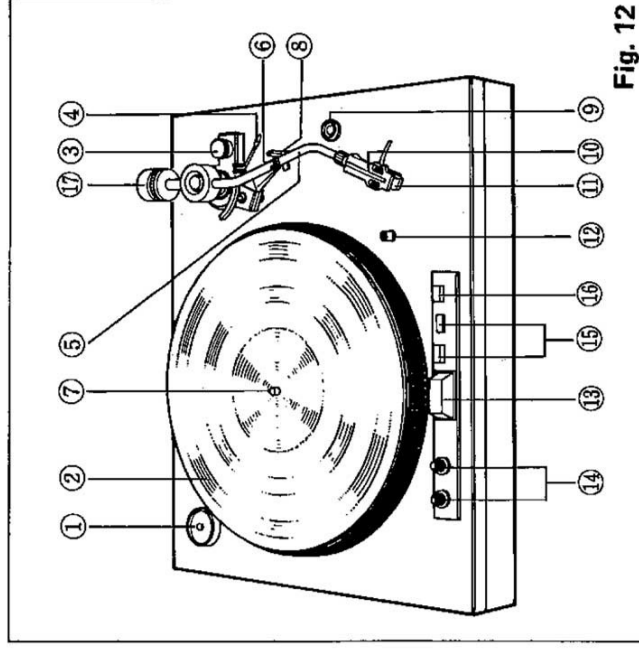

Fig. 12

#### ● OPERATION CONTROL

Set the controls on the amplifier or the receiver in your music system ready for operation. Set the **VOLUME** control to **MINIMUM** prior to operating the turntable.

1. Place a disc on the turntable.
2. Select the turntable speed by pushing the 33 or 45 button.
3. Raise the cueing lever to the up position and the tonearm will rise from its rest and move until it stops above the record.
4. Lower the cueing lever to the down position, and the tonearm will descend gently onto the record and performance will begin.
5. At the end of performance, the tonearm will automatically rise and return to the tonearm rest.

#### ● TO INTERRUPT PERFORMANCE

Raise the cueing lever to the up position and the tonearm will rise from the record and stay there.

Push the lever to down, and the tonearm will descend onto the record and performance will be resumed.

#### ● TO END OPERATION IN MIDST OF PERFORMANCE

A push of the **REJECT** button will cause the tonearm to rise and then swing back to the initial position. The turntable will stop rotating as the tonearm descends onto the tonearm rest.

#### NOTE:

Please refrain from touching the tonearm while it is re-turning automatically to the tonearm rest.

#### CLEANING AND GENERAL REMARKS

- Do not touch the turntable while it is running.
- Do not attempt to obstruct turntable rotation. This may cause the motor to become overheated or the belt to become deformed.
- Handle the power cord carefully.
- Do not touch the power cord with a wet hand.
- Grasp the plug when disconnecting the power cord from and AC outlet.
- Do not wet the turntable unit.

Moisture is detrimental to the safe and satisfactory operation of this automatic turntable. If it becomes wet, unplug the power cord immediately and bring it to a SANYO store or service center. Moisture can cause electric shock, fire hazards and mechanical breakdown.

- Do not modify your turntable unit.
- Do not attempt to repair or modify your automatic turntable unit by yourself but have it serviced by SANYO-authorized personnel.
- Poor workmanship will result in operating hazards and the breakdown of your unit.
- When your automatic turntable is not to be used for a while, be sure to return the tonearm to the tonearm rest and lock it with the lock lever.
- Power supply is automatically switched off when the tonearm is positioned on the tonearm rest. It should be locked when the turntable is out of operation so as to prevent the unit from being switched on by accident.
- No frequency control is required.
- Since your automatic turntable is powered by a DC servo motor, it runs at a constant speed irrespective of changes in frequency. No modification is needed when the turntable is operated at a different frequency rating.

- Keep the stylus clean.

The stylus used on your automatic turntable is highly sensitive and should always be kept clean, because dust accumulated on it will result in the deterioration of sound quality.

Use a soft brush when cleaning the stylus.

Check the stylus regularly for wear and damage, and replace it, if necessary. Refrain from handling the stylus carelessly.

- Keep the records clean.

For the enjoyment of high-quality sound, keep your records clean. Clean them of dust with a soft brush. If they become stained, wipe their surfaces with a soft cloth rinsed in water and wrung dry.

- Listen for howling.

Speakers may produce a howling sound if they are placed improperly in relation to the turntable unit. For the best sound, position the speakers as far away from the turntable as possible.

Resonance can be prevented by positioning the speaker boxes and the turntable on separate and rigid boards.

- Take good care of your automatic turntable.

Clean the cabinet and dust cover of your turntable unit, wiping them with a soft cloth. If they are very dirty or stained, use a soft cloth rinsed in water or diluted synthetic detergent. Never use volatile oil or alcohol since they will cause discoloration or surface cracking.

- Contact SANYO dealers or service centers for advice.

Unplug the power cord if any sign of trouble has been noticed. This precaution will prevent minor mechanical trouble into a costly major breakdown.

Minor troubles can be remedied by following the instructions given in the trouble-shooting section.

Never attempt to disassemble your automatic turntable and make repairs of its circuitry or mechanism. Contact a SANYO store or service center to have your unit serviced by authorized personnel.

#### CARTRIDGE REPLACEMENT AND ADJUSTMENT

- REPLACEMENT OF STYLUS (Fig. 13)

We recommend that you use the ST-28D diamond stylus, which is available from SANYO.

Under normal operating conditions, the stylus has a service life of 400 to 500 operating hours, although its durability varies significantly due to various factors. Check the stylus regularly for wear and damage, because a worn-out or damaged stylus will not only produce noise but will chisel the grooves of your records. Early replacement of the stylus will provide your records with the best protection and increase listening pleasure.

- STEPS FOR STYLUS REPLACEMENT

- (1) Be sure to switch off the amplifier hooked to the turntable.
- (2) Loosen the round nut and disconnect the head shell.
- (3) Hold the head shell with thumb and forefinger. Pull the stylus gently out of the head shell.
- (4) Insert a new stylus into the head shell. Never push it in forcibly.
- (5) Press the head shell lightly against the arm and refasten it there by tightening the round nut.

#### NOTE:

Use the SANYO ST-28D diamond stylus for highest-quality sound reproduction and for the protection of your records.

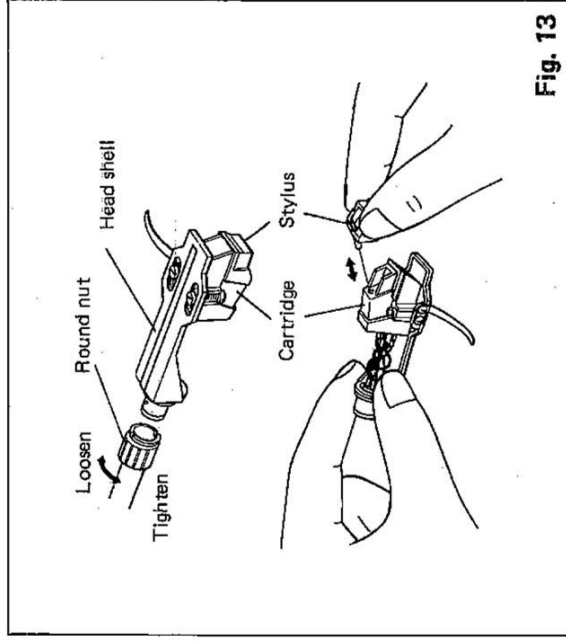

**Fig. 13**

● **REPLACEMENT OF CARTRIDGE (Fig. 14)**

Since the cartridge is incorporated into the head shell, it is recommended that the two be replaced together.

The new head shell-cartridge assembly can simply be attached to the tonearm.

To replace the cartridge alone, go through the following steps:

- (1) Loosen the round nut on the tonearm and detach the head shell.
- (2) Disconnect the lead wires carefully from the cartridge pins, holding the metal tip of each lead wire with a pair of pliers.
- (3) Remove the bolts fastening the cartridge to the head shell.
- (4) Set a new cartridge into the head shell. Do not fasten the cartridge tightly since its overhang is to be adjusted later on.

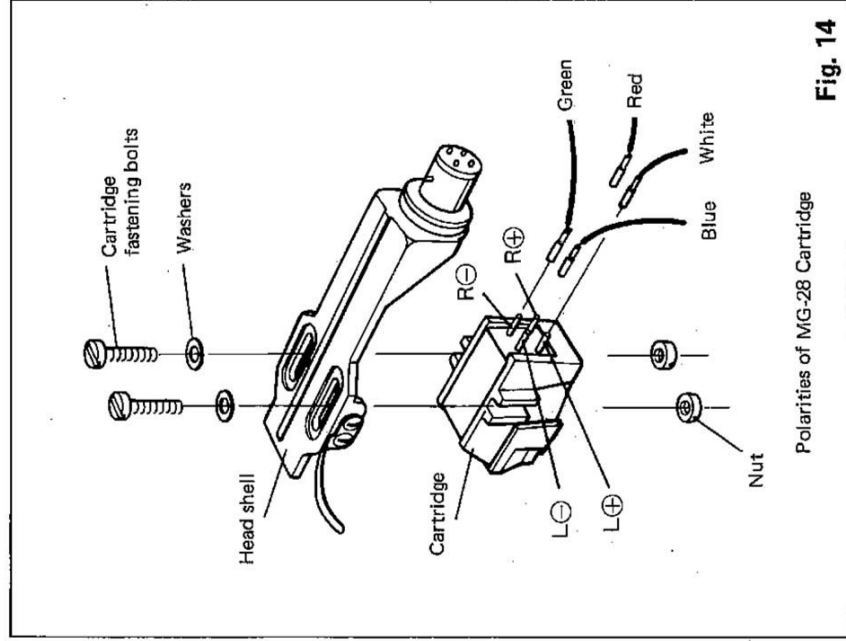

Polarities of MG-28 Cartridge

**Fig. 14**

- (5) Connect the four lead wires correctly to the cartridge pins. They are colored for ease of identification.

- White lead wire . . . . . L (+) (Left channel (+))
- Blue lead wire . . . . . L (-) (Left channel (-))
- Red lead wire . . . . . R (+) (Right channel (+))
- Green lead wire . . . . . R (-) (Right channel (-))

- (6) Adjust the cartridge for proper overhang. (cf. "Adjustment of overhang")

● **APPLICATION OF CARTRIDGE**

The tonearm of this automatic turntable has an adjustable counterweight which can offset the combined weight of the head shell and the cartridge within a range of 11 to 19 grams. Since the head shell alone weight 7 grams, the weight of the cartridge to be used must be 4 to 12 grams.

● **ADJUSTMENT OF CARTRIDGE FOR CORRECT OVERHANG**

After each replacement, the new cartridge must be adjusted for proper overhang. This is necessary for the accurate positioning of the stylus in order to reproduce distortion-free sound. (Fig. 15)

• Prior to making cartridge adjustment, unplug the power cord so the turntable cannot start to rotate.

- (1) Set the cartridge on the head shell and lightly secure the fastening bolts. Do not tighten the bolts strongly.
- (2) Lift the tonearm off its rest and position it just above the overhang point.
- (3) Hold the cartridge with your fingers and slide it to the fore or to the rear until the stylus is exactly above the center of the overhang point.
- (4) Return the tonearm to its rest and lock it there. Fasten the cartridge securely in its position by tightening the fastening bolts.

**NOTE:**

After each replacement of the stylus or the cartridge and after each adjustment of the cartridge for correct overhang, the stylus pressure should be corrected. (cf. "Adjustment of tonearm")

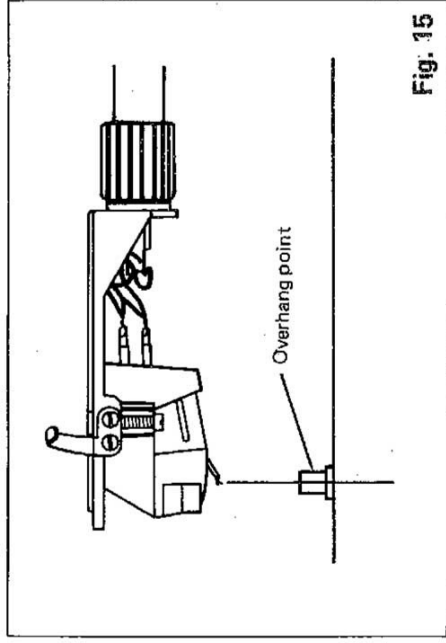

**Fig. 15**

**ABOUT SANYO**

Sanyo is one of the world's largest manufacturers of quality electronic equipment. Our products include television receivers, radios, high fidelity audio equipment, stereo equipment automobile stereo equipment, and tape recorders.

## TROUBLE-SHOOTING GUIDE

Prior to having your automatic turntable unit serviced, be sure to check the following and make corrections, if possible, according to the instructions.

Trouble	Cause	Correction
* Turntable does not rotate.	* Faulty plug-socket connection. * Belt is not on pulley.	* Insert plug into socket. * Put belt on pulley.
* No sound is produced.	* Output cords are not connected. * Improper head shell attachment. * Faulty lead wire connections to head shell.	* Connect cords to amplifier. * Plug head shell into tonearm and fasten it securely. * Re-connect lead wires.
* Noise is audible and there is marked sound distortion in high tonal range.	* Dust accumulation on stylus. * Dusty or scratched disc surface. * Worn-out stylus. * Improper stylus pressure. * Loud treble sound.	* Brush off dust. * Play a new record. * Replace. * Adjust. (cf. P.2) * Adjust tonal quality.
* Humming sound comes out of speakers while playing a record.	* Turntable and amplifier are not connected with ground wire. * Poor output cord connections.	* Connect turntable and amplifier with ground wire at ground terminals. (In some cases, better sound effect is produced when they are not connected with ground wire.) * Connect output cords to amplifier correctly.
* Speakers howl when sound volume is increased.	* Improper locations of speakers in relation to turntable (cf. P.4)	* Put speakers at a distance from turntable on solid foundations.

## SPECIFICATIONS (Nominal)

### MOTOR & TURNTABLE SECTION

Motor DC Servo Motor  
 Drive System Belt Drive  
 Speeds 33-1/3 & 45 rpm  
 Speed Change Electronic Control  
 Turntable Platter Aluminum Alloy Die-Cast  
 Diameter 308 mm  
 Weight 0.7 Kg  
 Wow & Flutter 0.05 %  
 Signal to Noise Ratio 60 dB  
 Speed Adjustment Range  $\pm 3.0$  %

### TONEARM SECTION

Type Static Balance Type (S-Shape)  
 Effective Length 222 mm  
 Cue Control Viscous Damped (Down Only)  
 Anti-Skating System Calibrated - Spring Type  
 Cartridge Weight Range 20 gr  
 with Headshell  $\pm 1.5$   
 Minimum Tracking Pressure 0 to 2.5 gr  
 Tracking Error 0 to 3.0 gr  
 Counterweight Calibration 0 to 4.0 gr  
 Antiskate Calibration

### CARTRIDGE SECTION

Type Induced Magnet Type (MG-28)  
 Frequency Response 10 Hz to 27 KHz  
 Channel Separation at 1 KHz 28 dB  
 Output Voltage 2.0 mV  
 Load Impedance 50 Kohm  
 Stylus 0.5 mil, Diamond (ST-28D)  
 Compliance at 1 KHz 5.1 x 10<sup>-6</sup> cm/dyne  
 Tracking Force 1.5 to 2.5 gr  
 Weight with Stylus 6 gr

### GENERAL

Power Requirement AC: 110/120/220/240 V, 50/60 Hz  
 Power Consumption 4 W  
 Dimension (W)x(D)x(H) 17-1/4"x6"x15"  
 Weight 15.2 lbs.

\*Specifications are subject to change without notice.

## CAUTION

This model is already set for a fixed voltage level. If it is used in a different voltage area from that indicated on the power cord label, the setting should be changed. To alter the voltage, remove the cover of the selector and change the voltage selector to the right position which corresponds to your local power.



SANYO ELECTRIC CO., LTD.

1316-4119-55402  
Printed in Japan